

This question paper contains 8 printed pages]

BR—172—2016

FACULTY OF SCIENCE

M.Sc. (First Year) (Second Semester) EXAMINATION

NOVEMBER/DECEMBER, 2016

(CBCS Course)

CHEMISTRY

Paper II (CH-422)

(Organic Chemistry)

(Saturday, 19-11-2016)

Time : 10.00 a.m. to 1.00 p.m.

Time—Three Hours

Maximum Marks—75

N.B. :— (i) Attempt All questions.

(ii) Figures to the right indicate full marks.

(iii) Use of Logarithmic table and calculator is allowed.

(iv) Multiple choice questions (MCQ) should be attempted only once on page No. 3 of answer-book with complete answer.

1. Answer any *three* of the following : 15

(a) 3-Hexyne is react with diborane and acetic acid gives cis-alkene (cis-3-Hexyne).

(b) Lithium aluminium hydride reduce cinnamaldehyde into 3-phenyl 1-propanol.

(c) Interconversion of 1, 3, 5 Hexatriene \rightleftharpoons 1, 3-cyclohexadiene under thermal and photochemical condition can be explained by FMO method.

P.T.O.

- (d) Explain cis-ae 1, 2-dimethyl cyclohexane is more stable than trans-aa 1, 2-dimethyl cyclohexane.
- (e) Cycloaddition reaction between two ethylene molecule by FMO method. Explain.

2. Answer any *three* of the following : 15

- (a) Why addition of HX on alkenes is regioselective reaction ?
- (b) When trans-2-methyl cyclohexanol is subjected to acid catalysed dehydration, the major product is 1-methylcyclohexene while trans 1-bromo 2-methyl cyclohexane is subjected to dehydrohalogenation, the major product is 3-methyl cyclohexene ? Explain.
- (c) Cope rearrangement is an intramolecular process. Explain.
- (d) Explain the stereochemistry of Biphenyl and Allenes.
- (e) Thermal dimerisation of 1, 3-butadiene yield endoform as a main product.

3. Explain the following : 7

- (a) With the help of corelation diagram and PMO method, show that Diels-Alder reaction is thermally allowed process.

Or

Illustrate with mechanism for the following reaction :

- (i) Wittig Reaction
- (ii) Stobbe Condensation.

- (b) Indicate whether the relationship in each pair of compounds below is identical, enantiomeric or distereomeric by assigning R and S configuration and E and Z configuration : 8

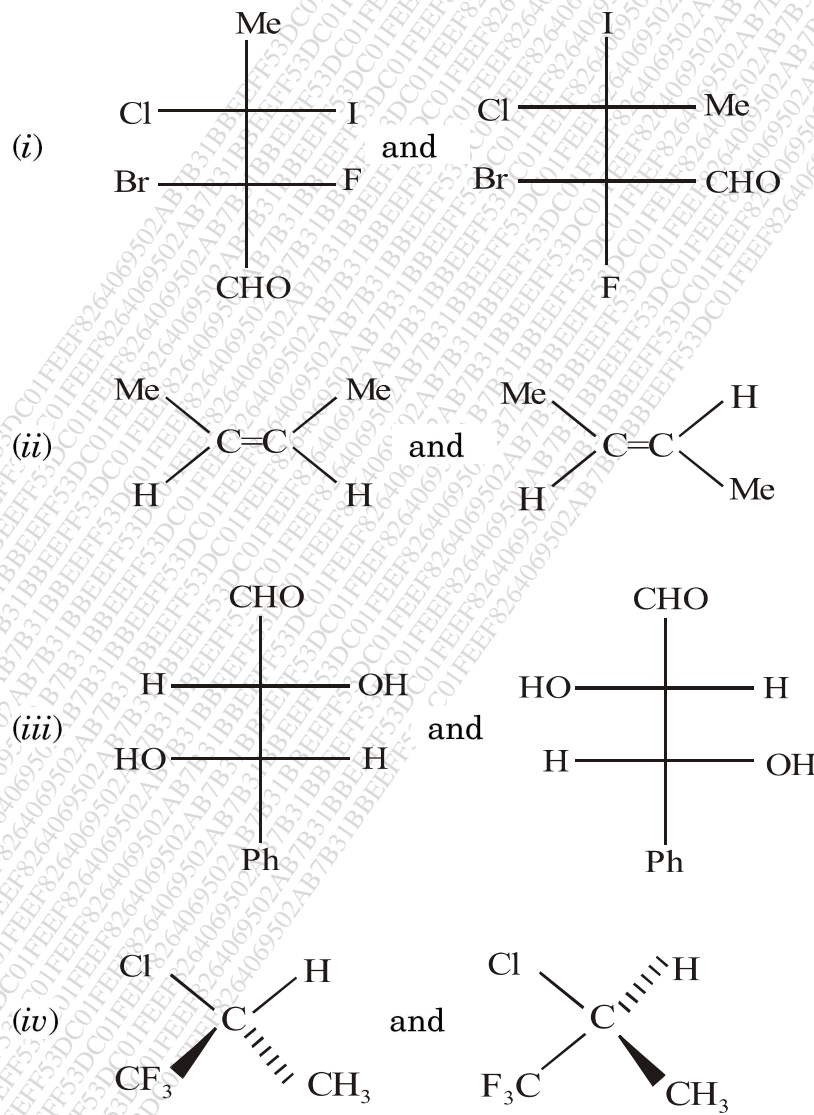

P.T.O.

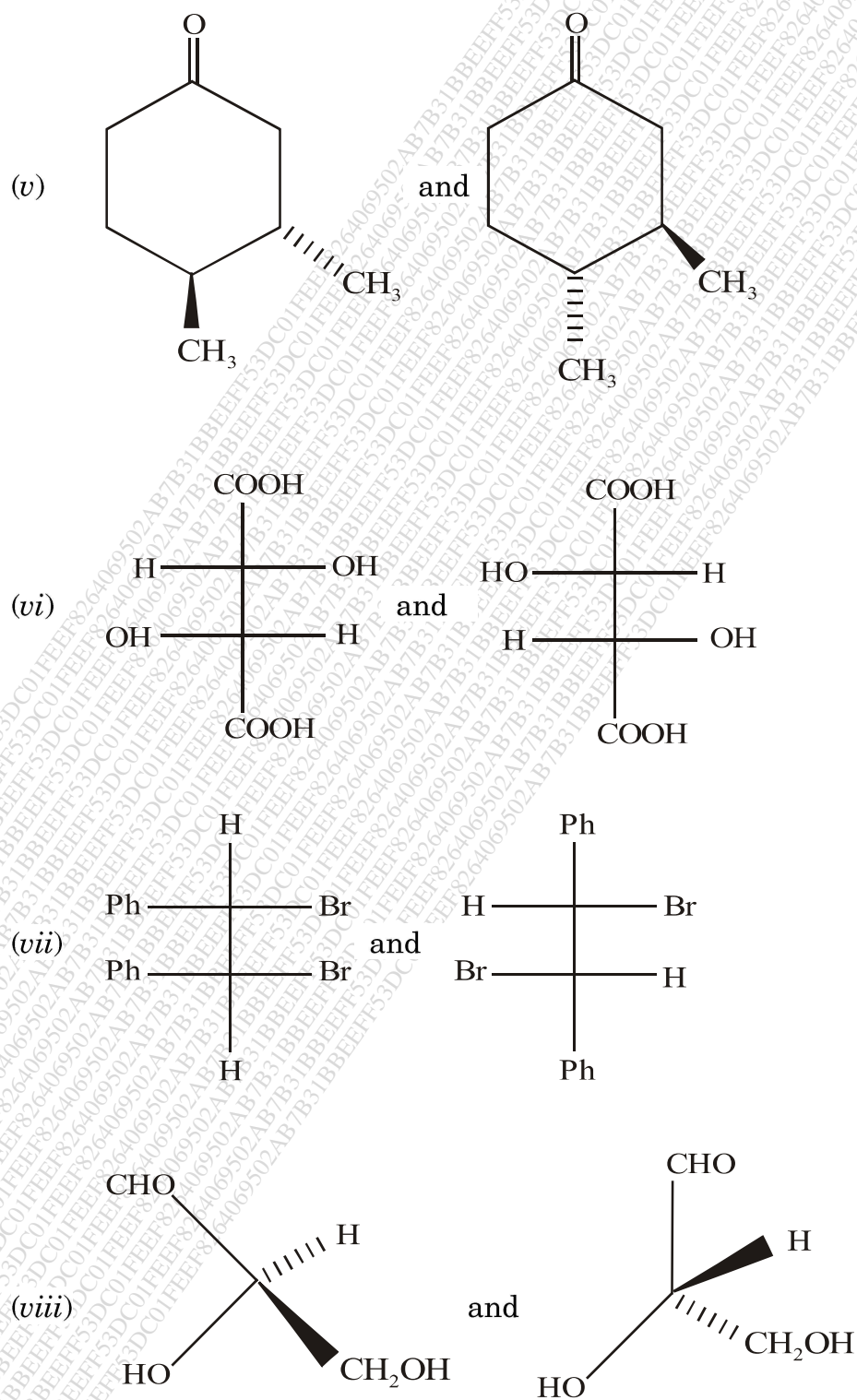

4. (a) Explain the order of stability of the following by assigning Gauche interaction : 7

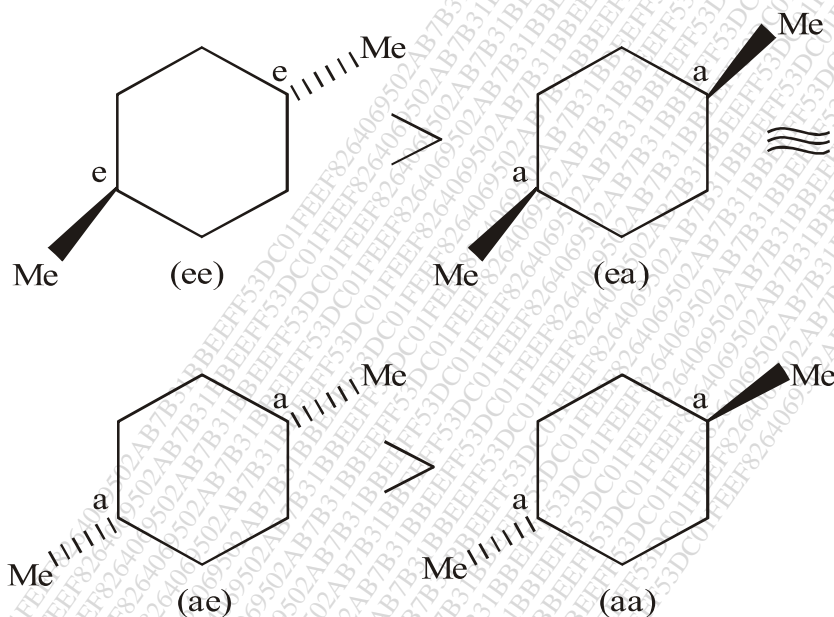

Or

Explain the following reactions with mechanism :

- (i) Mannich Reaction
 (ii) Michael addition reaction.

- (b) Predict the products with appropriate mechanism of the following (any four) : 8

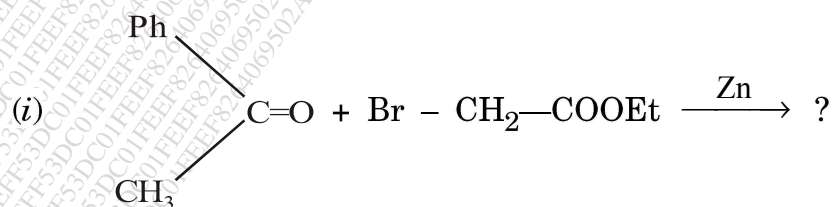

P.T.O.

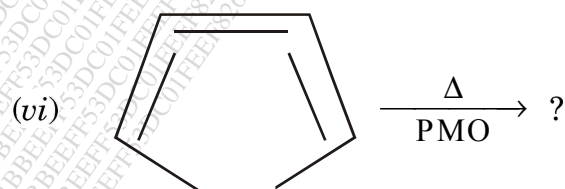
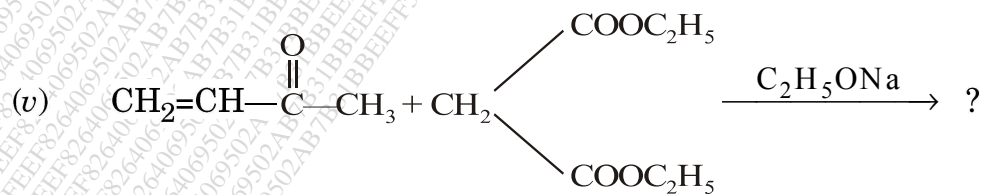
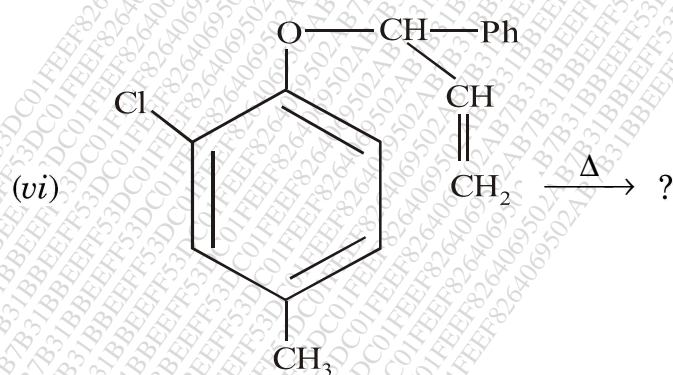
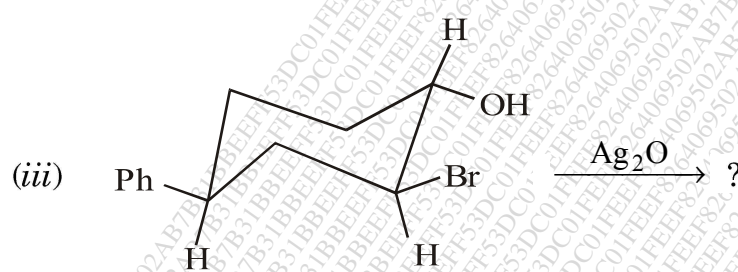
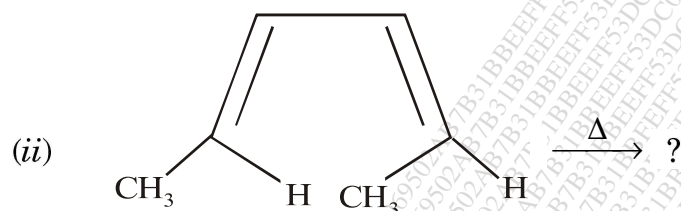

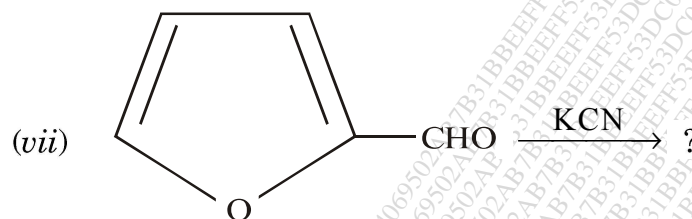

5. (A) Select the correct answer from the given options for each of the following : 5

(i) In which compound electrophilic addition takes place according to anti-Markovnikov's rule.

- (1) $\text{CH}_2=\text{CH}-\text{NO}_2$
 (2) $\text{CH}_2=\text{CH}-\text{CHO}$
 (3) $\text{CH}_2=\text{CH}-\text{CH}=\text{CH}_2$
 (4) $(\text{NO}_2)_2\text{C}=\text{C}(\text{NO}_2)_2$

- (a) (1) and (3) (b) Only (2)
 (c) Only (4) (d) (1), (2) and (3)

(ii) Pyrolysis of Xanthate ester is known as :

- (a) Cope Elimination (b) Hofmann Elimination
 (c) Saytzeff Elimination (d) Chugaev Elimination

(iii) [1, 5] Antrafacial Shift can occur via a transition state with :

- (a) 0 node 6 electron (b) 1 node 6 electron
 (c) 2 node 6 electron (d) None of these

P.T.O.

- (iv) Photocycloaddition of $(4n + 2)\pi$ system process by :
- (a) CON (b) DIS
- (c) C_2 -axis symmetry (d) None of these
- (v) The rate of Nitration of benzene is
- (a) Less than chlorobenzene but faster than that of anisole
- (b) Less than both chlorobenzene and anisole
- (c) Faster than chlorobenzene but less than anisole
- (d) None of the above

(B) Write short notes on any *two* of the following :

10

- (a) Cheletropic cycloaddition reactions of carbene
- (b) Stereochemistry of spiranes
- (c) Sharpless Epoxidation.